

Engineering Specification

Job Name _____

Contractor _____

Job Location _____

Approval _____

Engineer _____

Contractor's P.O. No. _____

Approval _____

Representative _____

LEAD FREE*

Models OF110-1, OF120-2 and OF140-4

OneFlow® Anti-Scale System

Connection Sizes: ½" and ¾"

Nominal Flow Rates: Up to 4 gpm (15.1 lpm)

These OneFlow® systems are single cartridge-based systems that must be installed on a cold water line** prior to the equipment they are protecting.

OneFlow prevents scale by transforming dissolved hardness minerals into harmless, inactive microscopic crystal particles. These crystals stay suspended in the water, have a greatly reduced ability to react negatively like dissolved hardness does, and eventually find their way to the drain. The system requires very little maintenance, no backwashing, no salt and no electricity. Typical hardness problems, especially build-up of scale in pipes, water heaters, boilers and on fixtures are greatly reduced.

OneFlow is not a water softener. It does not add chemicals to the water. It is a scale prevention device with proven third party laboratory test data and years of successful residential and commercial installations. OneFlow is the one water treatment device that effectively provides scale protection and is a great salt-free alternative to water softening (ion exchange) or scale sequestering chemicals.

Features

- Chemical free scale prevention and protection – converts hardness minerals to harmless, inactive microscopic crystals making OneFlow an effective alternative technology to a water softener for the prevention of scale due to water hardness
- Virtually maintenance free – No salt or other chemicals to constantly add or maintain
- No control valve, no electricity and no wastewater
- Uses environmentally friendly “green” technology
- Improves efficiency of all water appliances whether heating the water or not
- Simple sizing & installation – all you need to know is pipe size and flow rate
- Excellent systems for restaurants, cafeterias and coffee shops where multiple or single equipment protection is desired for longer equipment life and reduced energy consumption
- Inlet ball valve is included for easy isolation shutoff and filter changes
- OneFlow does not remove the essential minerals in water that are linked to good health
- OneFlow cartridge-based systems are simple to maintain; change the cartridge once per year



OneFlow media is certified by WQA to NSF/ANSI/CAN Standard 61 and NSF/ANSI 372 for Lead Free compliance.

C US

NOTICE

**For hot water applications where water temperature is 100°F - 140°F (38°C - 60°C), please consult ES-OneFlow-Hot Water.

⚠ WARNING

Do not use with water that is microbiologically unsafe or of unknown quality without adequate disinfection before or after the system.

*The wetted surface of this product contacted by consumable water contains less than 0.25% of lead by weight.

Watts product specifications in U.S. customary units and metric are approximate and are provided for reference only. For precise measurements, please contact Watts Technical Service. Watts reserves the right to change or modify product design, construction, specifications, or materials without prior notice and without incurring any obligation to make such changes and modifications on Watts products previously or subsequently sold.

Specifications

A OneFlow® scale prevention system shall be installed on the cold water service line to condition the tap water just prior to the equipment it is designed to protect. The system will be sized for maximum or peak flow rate based on the specification of said equipment. A OneFlow system may also be installed to protect multiple pieces of equipment from the ill-effects of hard water scale provided the aggregate peak flow rate for each piece of equipment it is protecting has been considered. The system shall be plumbed with a bypass valve to allow isolation of filter housing to allow the bypass of untreated water in the event that service or cartridge replacement be necessary. The installation area should be suitable in size for the housing to be serviced without encumbrance and the system should be installed per the Installation, Operation & Maintenance manual as provided with each system.

The OneFlow system must not require additional waste water to backwash, flush, or regenerate once put into service. The system shall not require any chemical additives and shall not require electricity for operation.

Models

Model	Maximum Flow Rate	Connection sizes
OF110 – 1	1 gpm (3.8 lpm)	½" FNPT
OF120 – 2	2 gpm (7.6 lpm)	½" FNPT
OF140 – 4	4 gpm (15.1 lpm)	¾" FNPT

Replacement Cartridge

OF110RM	Cartridge should be replaced every 12 months
OF120RM	Cartridge should be replaced every 12 months
OF140RM	Cartridge should be replaced every 12 months

⚠ WARNING

Using OneFlow with Other Water Treatment Equipment

Due to the unique properties of OneFlow, there are some unique requirements for using OneFlow in conjunction with filtration or other forms of water treatment.

- OneFlow must be the last stage in the treatment chain. Do not install any filters after OneFlow or before any devices for which scale prevention is required. POU filters, e.g. carbon, RO or Ultraviolet (UV) are exempt from this requirement.
- Do not apply any other antiscalants before or after OneFlow.
- The addition of soaps, chemicals, or cleaners, before or after OneFlow treatment, may reverse its anti-scale treatment effects and/or create water with a heavy residue or spotting potential. Any adverse conditions caused by the addition of soaps, chemicals, or cleaners are the sole responsibility of the end user.
- OneFlow is not a water softener and does not soften the water - Water treatment chemistry (e.g. antiscalants, sequestrants, soaps, chemicals or cleaners etc...) will most likely have to be changed to be compatible with OneFlow treated water. Laundry and ware-washing chemistry will likewise require adjustments.

Standards

Independent scientific testing has confirmed media-assisted crystallization (MAC) technology provides scale reduction of over 95+%. Testing was conducted under protocol based on DVGW W512 test to access control of scale formation.

Feed Water Chemistry Requirements

pH	6.5-8.5
Hardness (maximum)	30 grains (513 ppm CaCO ₃)*
Water Pressure	10psi to 90psi (0.69 bar to 6.2 bar)
Temperature	40°F to 100° F (5°C to 38°C)
Free Chlorine	<2 ppm
Iron (maximum)	0.3 ppm**
Manganese (maximum)	0.05 ppm**
Copper (maximum)	1.3 ppm***
Oil & H ₂ S	Must be Removed Prior to OneFlow
Total Phosphates	<3.0 ppm
Silica (maximum)	20 ppm †
TDS	<1500 mg/L ††

NOTICE

Not for use on closed loop systems.

* Systems using OneFlow cartridge technology are effective at controlling lime-scale formation inside the plumbing system at influent hardness levels up to 30 grains per gallon (513 ppm) as calcium carbonate. Due to variances in water chemistry, 30 grains per gallon is a recommended hardness maximum due to potential aesthetic issues related to soft scale residue formation outside of the plumbing system. Testing should be performed to determine proper application where hardness levels exceed 30 grains per gallon.

* Just as with conventional water softening media, OneFlow media needs to be protected from excess levels of certain metals that can easily coat the active surface, reducing its effectiveness over time. Public water supplies rarely, if ever, present a problem, but if the water supply is from a private well, confirm that the levels of iron (Fe) and manganese (Mn) are less than 0.3 mg/L and 0.05 mg/L, respectively.

⚠ WARNING

***Pursuant to the EPA drinking water standards, the copper concentration permitted is up to 1.3 ppm. Typically originating from new copper plumbing, high levels of copper can foul OneFlow media. New Copper lines need to be passivated for a minimum of 4 weeks before placing unit into service. For applications with copper concentration greater than 1.3 ppm, please consult Watts® Water Quality Technical Service. To further minimize any problem with excess copper, avoid applying excessive flux on the inner surfaces of the pipe and use a low-corrosivity water soluble flux listed under the ASTM B813 standard.

NOTICE

† OneFlow media does not reduce silica scaling. While silica tends to have a less significant effect on scale formation than other minerals, it can act as a binder that makes water spots and scale residue outside the plumbing system difficult to remove. This 20 ppm limitation is for aesthetic purposes.

†† All other contaminants must meet the requirements of the USEPA Safe Drinking Water Act. Specific Mineral and Metal MCL's, identified in Watts published Feed Water Chemistry Requirements, supersedes the USEPA SDWA.

Water known to have heavy loads of dirt and debris may require pre-filtration prior to OneFlow.

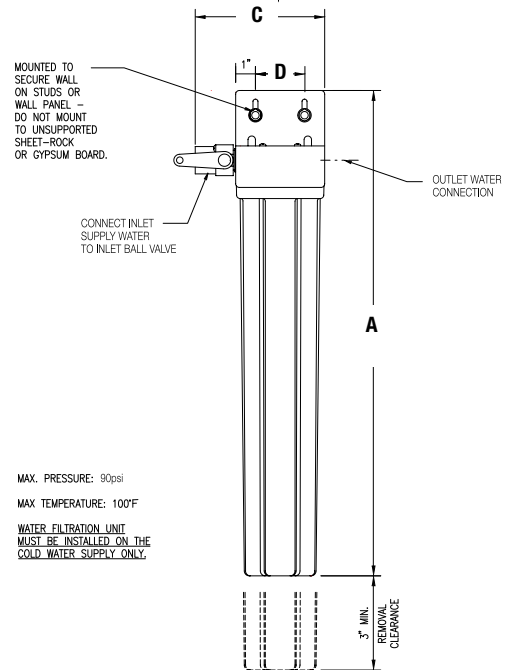
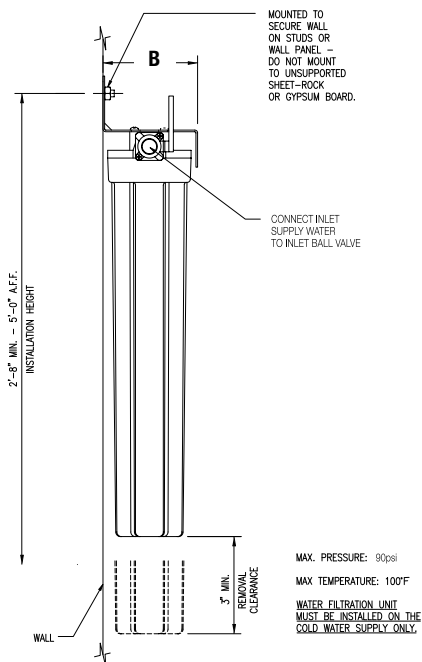

MAX. PRESSURE: 90psi
 MAX TEMPERATURE: 100°F
 WATER FILTRATION UNIT
 MUST BE INSTALLED ON THE
 COLD WATER SUPPLY ONLY.

Dimensions

Call customer service if you need assistance with technical details.

Model	Ordering Code	Dimensions							
		A		B		C		D	
		<i>in.</i>	<i>cm</i>	<i>in.</i>	<i>cm</i>	<i>in.</i>	<i>cm</i>	<i>in.</i>	<i>cm</i>
OF110-1	0002148	13½	34	5⅝	14	6¾	17	2⅝	6
OF120-2	0002149	25	64	5⅝	14	8	20	2¼	6
OF140-4	0002150	28⅞	71	8	20	9⅞	25	5¾	15

The overall height and the height of the inlet fitting varies due to material variations and assembly tolerances. Please allow additional clearance above the filter for making connections.

Peak Flow Rates — Weights

Model	*Maximum Flow		Dry Weight		Service Weight	
OF110-1	1 gpm	3.8 lpm	5 lbs.	2.3 kgs.	8 lbs.	3.6 kgs.
OF120-2	2 gpm	7.6 lpm	8 lbs.	3.6 kgs.	15 lbs.	6.8 kgs.
OF140-4	4 gpm	15.1 lpm	18 lbs.	8.2 kgs.	32 lbs.	15 kgs.

*Exceeding maximum flow can reduce effectiveness and void warranty.

NOTICE

The information contained herein is not intended to replace the full product installation and safety information available or the experience of a trained product installer. You are required to thoroughly read all installation instructions and product safety information before beginning the installation of this product.



USA: T: (800) 224-1299 • Watts.com
 Canada: T: (905) 332-4090 • Watts.ca
 Latin America: T: (52) 55-4122-0138 • Watts.com