

About Watts

Since its founding in 1874, Watts has developed a reputation of "Setting the Standard in Valve Technology." Through a family of companies, Watts Water Technologies, Inc. (collectively "Watts") designs and manufactures innovative products and systems in five application areas: Plumbing & Flow Control, Water Reuse & Drainage, HVAC, Water Quality, and Municipal Waterworks. Watts continues to create integrated solutions for water quality and conservation and to improve comfort, safety, and quality of life for people around the world through expertise in a wide range of water technologies.

Watts is a renowned global business with offices and manufacturing facilities in Europe, Asia-Pacific, and North America. Watts entered the Chinese market in 1994 and currently operates two facilities: Watts Water Equipment Manufacturing (Ningbo) Co., Ltd., and Watts (Ningbo) International Trading Co., Ltd., a distribution center. In 2007, Watts established its Asia-Pacific Middle East and Africa headquarters in Shanghai, China, and has set up operational branches in Beijing, Guangzhou, Singapore, Australia, South Korea, Dubai and Egypt.

Innovation is the gene of Watts, and it is the pursuit of Watts to meet the expectations of customers for high quality life. Watts offers a full range of valve solutions for HVAC, water supply and drainage systems for the building industry. For energy side systems, free cooling systems, computer room air handler systems, and comfortable air conditioning systems in data center, Watts offers a comprehensive solution for the water system in the data center, which can assist architects, design consultants, contractors, engineers, and equipment managers of the data center in creating safe, reliable, cost-effective, energy-saving, balancing and efficient systems.

For more information about Watts and Watts products, please visit Watts' official website at www.watts.com.

More Reliable, More Efficient

Solutions to Watts Liquid Cooling System



WATTS ASIA PACIFIC SALES PTE. LTD.

8 Marina Boulevard #05-02, Marina Bay Financial Centre, Singapore 018981

info.sea@wattswater.com

Series No.VL01EN2511



watts.cn



Solutions to Watts Liquid Cooling System

Liquid cooling system

With the increasing demand for high-performance computing such as AI computing and HPC computing, computing chips such as CPUs and GPUs are evolving towards high computing power and high integration, which also leads to a significant increase in the energy consumption of a single computing chip. Traditional air-cooling techniques present a bottleneck in high-heat-density scenarios, and the heat dissipation efficiency can no longer keep up with the computing efficiency. The application of liquid cooling can save energy consumption and reduce noise for data centers, provide high-density computing power, and improve the deployment density of single cabinets.

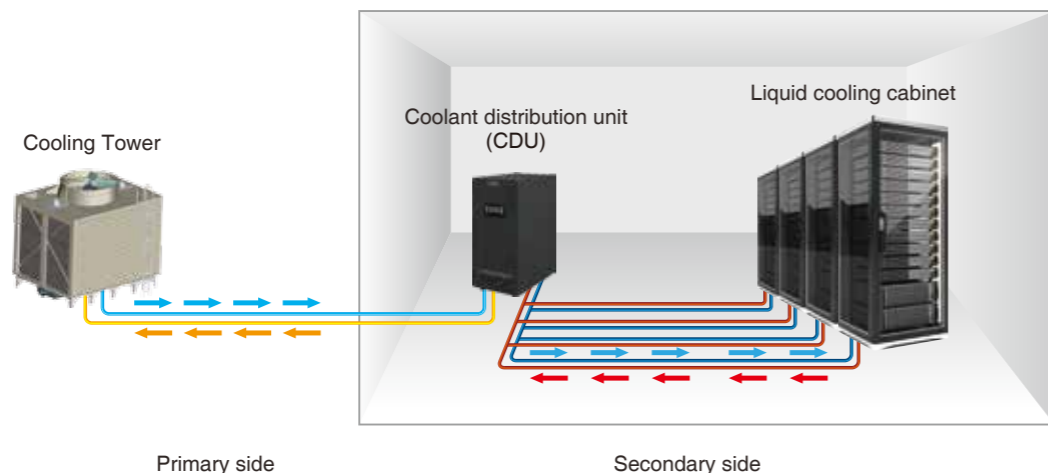

Solutions to secondary side of cold plate liquid cooling

Watts offers degreased and de-oiled stainless steel valves with welding or clamp connections to prevent corrosion and clogging, eliminating the need for materials like thread seal tape and sealant.

Solutions to CDU

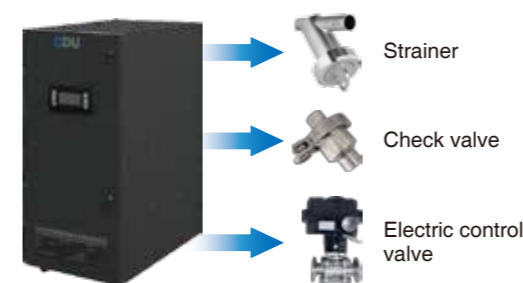

Isolation valve: Stainless steel butterfly valve with a compact design to save installation space. Various handles available to prevent layout interference.

Stainless steel ball valve: Full diameter design and low flow resistance; 3-piece structure for easy online maintenance.

Strainer: optional filtering accuracy to guarantee system security; large free area and small pressure loss.

Check valve: low opening pressure and reliable sealing.

Electric control valve: Equal percentage control characteristics and accurate control.

Solutions to pipeline system

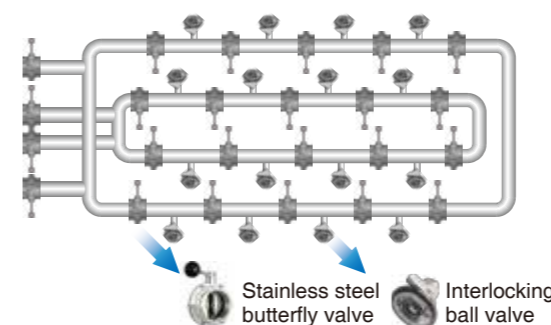

Stainless steel butterfly valve: The valve offers multiple optional structure types, a compact structure, reliable sealing, and rapid opening closing.

Interlocking ball valve: capable of opening and closing system pipelines without the need for tools.

Double foolproof design: to prevent misoperation, ensuring safety and reliability.

Solutions to liquid cooling cabinet

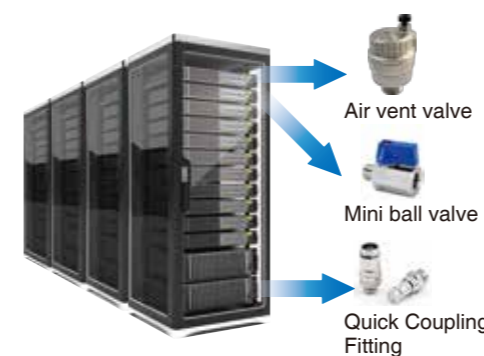

Air vent valve: Equipped with a built-in filter screen. This product offers reliable performance, safety, and efficiency.

Mini Ball Valve: Featuring one-piece construction and dependable sealing, this valve saves installation space.

Quick Coupling Fitting: This small-sized fitting offers low flow resistance and easy plug-and-pull functionality. Its non-dripping design enhances system security.

Series W7000

W7000-EN-202506

W7000-EN-202506

Stainless Steel Butterfly Valve

Size: DN15-DN200

W7000 series stainless steel butterfly valve is designed for isolation service in the pipeline. With welding and clamp connection types available for selection, the product is suitable for use in the fields of liquid cooling and industrial application.

Features

- Low resistance
- Convenient maintenance
- Low operation torque
- De-oiling and de-greasing

Materials

No.	Part	Material
1	Dust cover	PE
2	Bolt	Stainless steel
3	Nut	Stainless steel
4	Body	Stainless steel
5	Disc	Stainless steel
6	Seat	EPDM
7	Bushing	PA66
8	Rotator	Stainless steel
9	Spring	Stainless steel
10	Sleeve	Stainless steel
11	Handle	Stainless steel

Installation Dimensions

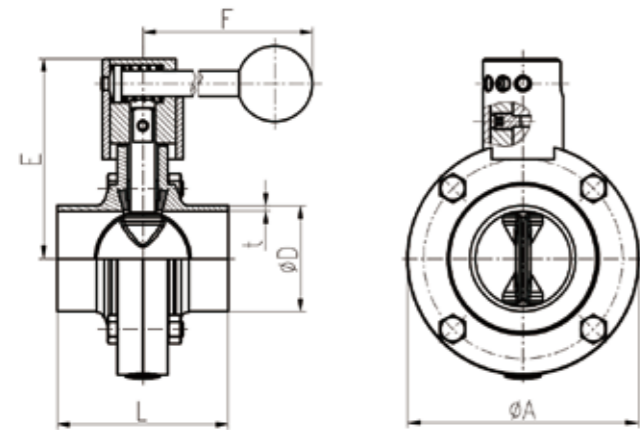

DIN welding

Type	DN	ØD	t	E	F	L	ØA
W7600	DN15	19	1.5	69	125	44	69
	DN20	23	1.5	69	125	44	69
	DN25	29	1.5	69	125	44	69
	DN32	35	1.5	73	125	44	76
	DN40	41	1.5	76	125	48	82
	DN50	53	1.5	84	125	48	98
	DN65	70	2	94	125	50	118
	DN80	85	2	102	160	56	134
	DN100	104	2	112	160	60	155
	DN125	129	2	130	180	70	185
	DN150	154	2	145	190	80	217
DN200	204	2	197	295	80	284	

ISO welding

Type	Size	ØD	t	E	F	L	ØA
W7600	3/4	19.05	1.5	69	125	44	69
	1	25.4	1.5	69	125	44	69
	1 1/4	31.8	1.5	73	125	44	76
	1 1/2	38.1	1.5	76	125	44	82
	2	50.8	1.5	84	125	50	98
	2 1/2	63.5	2	91	125	50	113
	3	76.2	2	97	160	56	125
	3 1/2	88.9	2	102	160	56	134
	4	101.6	2	112	160	60	155
	4 1/4	108	2	112	160	60	155
	4 1/2	114.3	2	112	160	60	155
5	127	2	130	180	70	185	



Pressure-Temperature

- Nominal pressure: PN10
- Temperature range: -10°C-100°C
- Connection standard: Welding: DIN 11850 / ISO 2037
Clamp: DIN 32676 / ISO 2852
- Test standard: EN 12266/ ISO 5208
- Suitable media: Water, ≤50% ethylene glycol

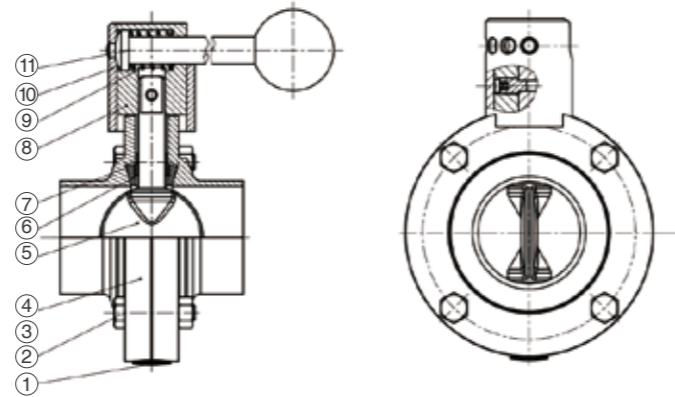

DIN clamp

Type	DN	ØD	Ød	E	F	L	ØA
W7800	DN15	34	27.5	69	125	66	69
	DN20	34	27.5	69	125	66	69
	DN25	50.5	43.5	69	125	66	69
	DN32	50.5	43.5	73	125	66	76
	DN40	50.5	43.5	76	125	68	82
	DN50	64	56.5	84	125	70	98
	DN65	91	83.5	94	125	70	118
	DN80	106	97	102	160	90	134
	DN100	119	110	112	160	94	155
	DN125	155	146	130	180	100	185
	DN150	183	174	145	190	100	217
DN200	233.5	225	197	295	100	284	

Note: *The dimension conforms to the common used standard in China. Confirm whether or not the dimensions of the provided clamp ring is consistent with this.

DIN welding - 3 piece

Type	DN	ØD	Ød	E	F	L	ØA
W7300	DN25	29	1.5	80	125	88	69
	DN32	35	1.5	84	125	88	76
	DN40	41	1.5	87	125	92	82
	DN50	53	1.5	95	125	92	98
	DN65	70	2	105	125	94	118
	DN80	85	2	111.5	150	104	134
	DN100	104	2	122	150	104	155
	DN125	129	2	148.5	170	120	185
	DN150	154	2	165.5	220	120	217
	DN200	204	3	198.7	295	120	284

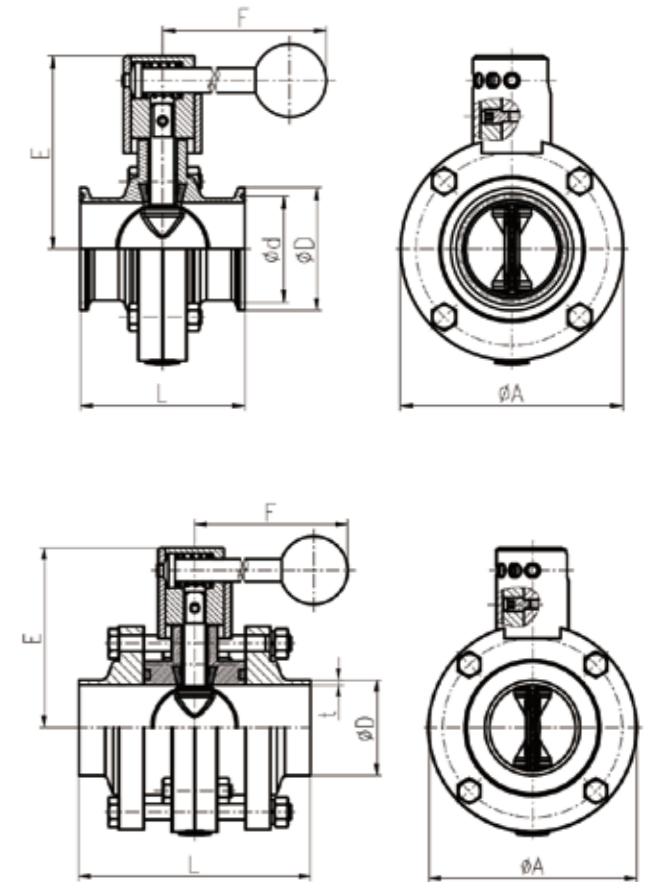

Series W6000

W6000-EN-202506

W6000-EN-202506

Stainless Steel Three-Piece Ball Valve

Size: DN15-DN100

W6000 series stainless steel three-piece ball valve is designed for isolation service in the pipeline. With welding and clamp connection types available for selection, the product is suitable for use in the fields of liquid cooling and industrial application.

Features

- Low resistance
- Convenient maintenance
- Low operation torque

Pressure-Temperature

- Nominal pressure: PN16(DN15-50) PN10(DN65-100)
- Temperature range: -10°C-100°C
- Connection standard: Welding: DIN 11850 / ISO 2037
Clamp: DIN 32676 / ISO 2852
- Test standard: EN 12266/ ISO 5208
- Suitable media: Water, ≤50% ethylene glycol

Materials

No.	Part	Material
1	Bonnet	Stainless steel
2	Bolt, spring washer, nut	Stainless steel
3	Body	Stainless steel
4	Seat	PTFE
5	Ball	Stainless steel
6	Stem	Stainless steel
7	Washer	PTFE
8	Filler	PTFE
9	Gland	Stainless steel
10	Handle	Stainless steel
11	Nut, spring washer	Stainless steel

Installation Dimensions

DIN Clamp

Type	DN	ØD	Ød	L	H	A	W
W6800	DN15	50.5	43.5	97	54.5	48	86
	DN20	50.5	43.5	108	63.5	55	96
	DN25	50.5	43.5	113.5	75.5	60	120
	DN32	50.5	43.5	124.5	82	72	128
	DN40	50.5	43.5	140	90	80	155
	DN50	64	56.5	154.5	98	91	175
	DN65	91	83.5	180	119	117	219
	DN80	106	97	206.5	131	137	229
	DN100	119	110	250	177	172	290

*Contact us for other clamp sizes



Welding



Clamp

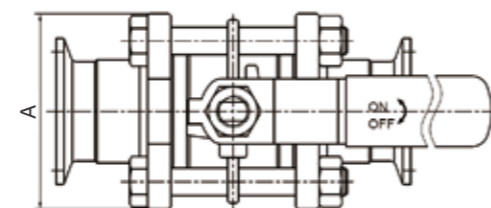
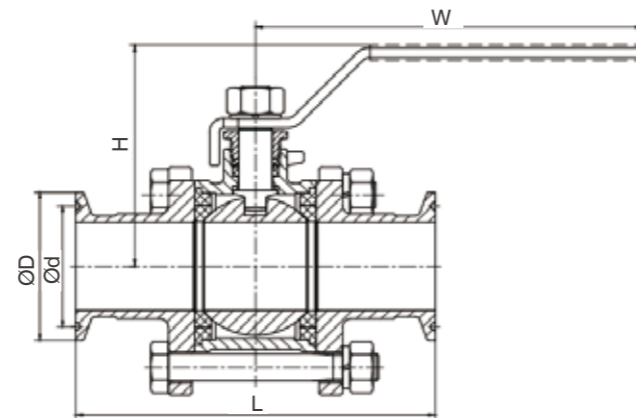
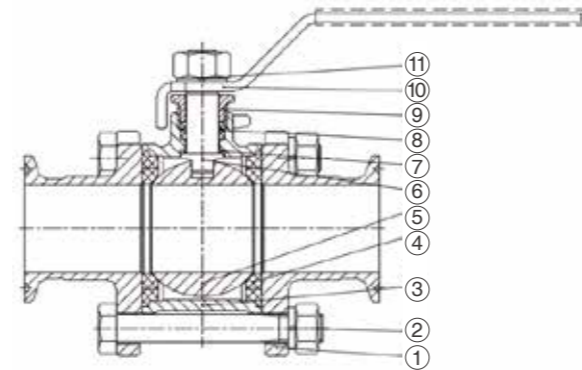

DIN Welding

Type	DN	ØD	t	L	H	A	W
W6600	DN15	19	1.5	70	54.5	48	86
	DN20	23	1.5	79	63.5	55	96
	DN25	29	1.5	90	75.5	60	120
	DN32	35	1.5	97.8	82	72	128
	DN40	41	1.5	111	90	80	155
	DN50	53	1.5	136.5	98	91	175
	DN65	70	2	181	118.5	117	219
	DN80	85	2	204	130.5	137	229
	DN100	104	2	260.5	176.5	172	289.5

ISO Welding

Type	Size	ØD	t	L	H	A	W
W6600	3/4	19.05	1.5	70	54.5	49	86
	1	25.4	1.5	79	63.5	56	96
	1 1/4	31.8	1.5	89.5	75.5	60	120
	1 1/2	38.1	1.5	97.8	82	68	128
	2	50.8	1.5	111	90	80	155
	2 1/2	63.5	1.5	136.5	98	91	175
	3	76.2	2.0	182	122	117	210
	3 1/2	88.9	2.0	204	133	137	240
	4	101.6	2.0	258.5	163.5	172	311

Butt-welding

Type	DN	ØD	Ød	L	H	A	W
W6600	DN15	22	14.5	72	51	49	106
	DN20	27	19	80	59	56	113
	DN25	32	24	90	64	60	127.5
	DN32	39.5	31	102	73	68	144
	DN40	47	39	112	86.5	80	163
	DN50	57	49	138	94.25	91	174.5
	DN65	75.5	66	182.5	118.5	117	219
	DN80	91	79	205	130.5	137	229
	DN100	110	98	260.5	176.5	172	289.5

Contact with us for other welding size

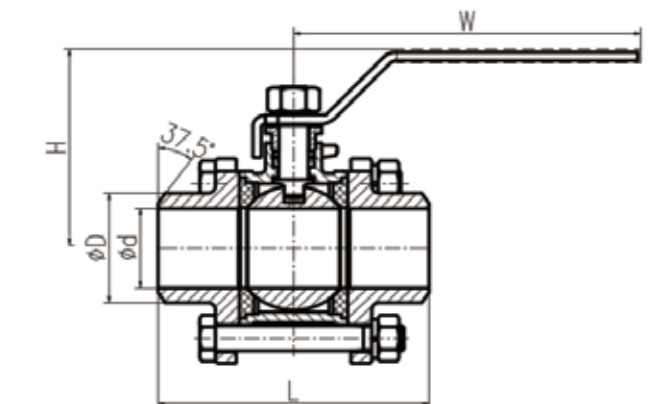
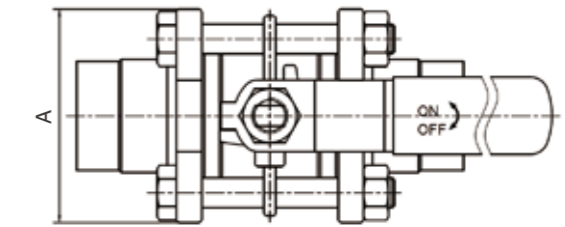
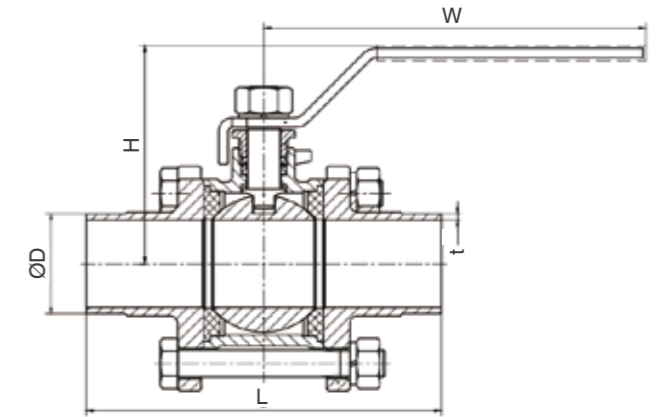

Series W2000

W2000-EN-202506

W2000-EN-202506

Stainless Steel Strainer

Size: DN15-DN100

W2000 series stainless steel strainer is designed to remove impurities in the medium to protect valve and equipment for normal use. With welding and clamp connection types available for selection, the product is suitable for use in the fields of liquid cooling and industrial application.

Features

- Low resistance
- Convenient maintenance
- Convenient sewage discharge
- De-oiling and de-greasing

Pressure-Temperature

- Nominal pressure: PN10
- Temperature range: -10°C-100°C
- Connection standard: Welding: DIN 11850 / ISO 2037
Clamp: DIN 32676 / ISO 2852
- Test standard: EN 12266/ ISO 5208
- Suitable media: Water, ≤50% ethylene glycol
- Filter screen: Hole diameter 48 μm, 300 meshes

Materials

No.	Part	Material
1	Body	Stainless steel
2	Sealing	EPDM(FKM optional)
3	Screen	Stainless steel
4	Bonnet	Stainless steel
5	Sealing	EPDM(FKM optional)
6	Nut	Stainless steel

Installation Dimensions

DIN welding

Type	DN	φD	t	L	φD1	H	A	A1
W2600	DN15	19	1.5	130	72	230	94.5	164.5
	DN20	23	1.5	130	72	230	96.5	166.5
	DN25	29	1.5	130	72	230	99.5	169.5
	DN32	35	1.5	140	82	235	105.5	170.5
	DN40	41	1.5	175	97	275	127.5	202.5
	DN50	53	1.5	210	111	320	145.5	240.5
	DN65	70	2	260	138	445	203	331
	DN80	85	2	300	148	500	206.5	341.5
	DN100	104	2	360	185	565	240	400

ISO welding

Type	OD	φD	t	L	φD1	H	A	A1
W2600	3/4	19.05	1.5	130	72	230	94.5	164.5
	1	25.4	1.5	130	72	230	97.3	167.3
	1 1/4	31.8	1.5	140	82	235	104.1	164.1
	1 1/2	38.1	1.5	175	97	275	126.0	201.0
	2	50.8	1.5	210	111	320	144.6	239.6
	2 1/2	63.5	2	245	125	405	183.3	298.3
	3	76.2	2	280	138	445	193.9	321.9
	3 1/2	88.9	2	300	148	500	200.6	335.6
	4	101.6	2	360	185	565	239.2	399.2
	4 1/2	114	2	485	240	700	325.0	478.0



Welding

Clamp

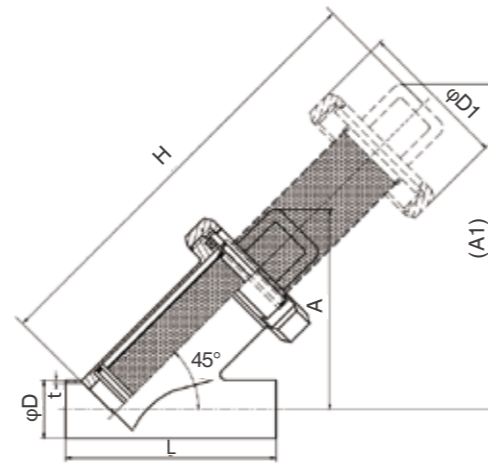
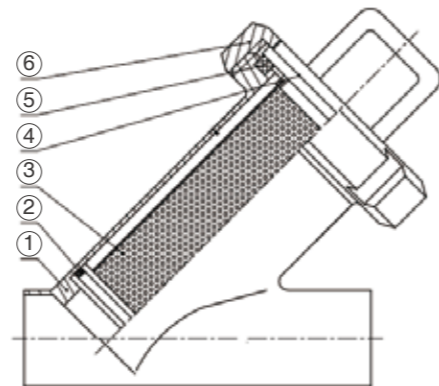

DIN clamp

Type	DN	φD	φd	L	φD1	H	A	A1
W2800	DN15	34/50.5	27.5/43.5	173	72	230	94.5	164.5
	DN20	34/50.5	27.5/43.5	173	72	230	96.5	166.5
	DN25	50.5	43.5	173	72	230	99.5	169.5
	DN32	50.5	43.5	183	82	235	105.5	170.5
	DN40	50.5	43.5	218	97	275	127.5	202.5
	DN50	64	56.5	253	111	325	145.5	240.5
	DN65	91	83.5	303	138	445	203	331
	DN80	106	97	343	148	500	206.5	341.5
	DN100	119	110	403	185	565	240	400

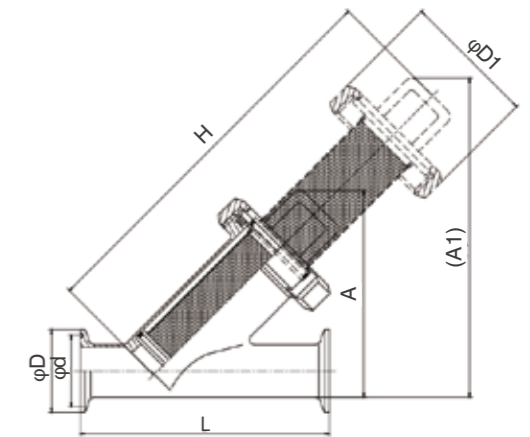

Series W5000

W5000-EN-202511

W5000-EN-202511

Stainless Steel Check Valve

Size: DN15-DN100

W5000 series stainless steel check valve is designed to protect against medium backflow. With welding and clamp connection types available for selection, the product is suitable for use in the fields of liquid cooling and industrial application.

Features

- Low resistance
- Convenient maintenance
- De-oiling and de-greasing

Pressure-Temperature

- Nominal pressure: PN10
- Temperature range: -10°C-100°C
- Connection standard: Welding: DIN 11850 / ISO 2037
Clamp: DIN 32676 / ISO 2852
- Test standard: EN 12266/ ISO 5208
- Suitable media: water, ≤50% ethylene glycol

Materials

No.	Part	Material
1	Body	Stainless steel
2	Seal	EPDM(FKM optional)
3	Dsic	Stainless steel
4	Spring	Stainless steel
5	Seat	Stainless steel
6	Clamp	Stainless steel
7	Seal	EDPM(FKM optional)
8	Bonnet	Stainless steel

Installation Dimensions

DIN welding

Type	DN	ØD	t	ØA	H
W5600	DN15	19	1.5	72	97
	DN20	23	1.5	72	97
	DN25	29	1.5	72	97
	DN32	35	1.5	72	97
	DN40	41	1.5	87	97
	DN50	53	1.5	102	97
	DN65	70	2	117	97
	DN80	85	2	139	101
DN100	104	2	166	107	

DIN welding

Type	Size	ØD	t	ØA	H
W5600	3/4	19.05	1.5	72	97
	1	25.4	1.5	72	97
	1 1/4	31.8	1.5	72	97
	1 1/2	38.1	1.5	87	97
	2	50.8	1.5	102	97
	2 1/2	63.5	2.0	117	97
	3	76.2	2.0	133.6	97
	3 1/2	88.9	2.0	139	101
4	101.6	2.0	166	107	



Welding

Clamp

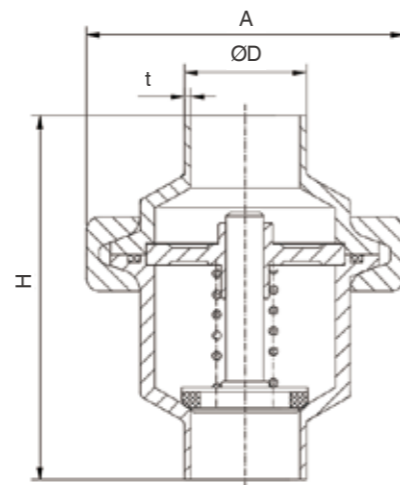
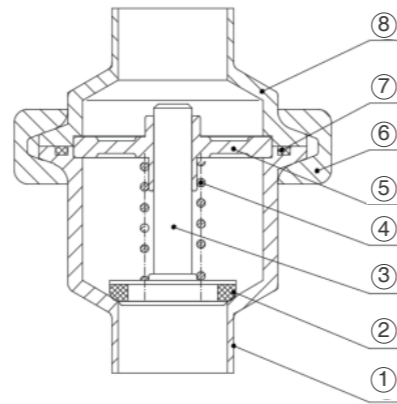

DIN clamp

Type	DN	ØD	Ød	ØA	H
W5800	DN15	34	27.5	72	97
	DN20	34	27.5	72	97
	DN25	50.5	43.5	72	97
	DN32	50.5	43.5	72	97
	DN40	50.5	43.5	87	97
	DN50	64	56.5	102	97
	DN65	91	83.5	117	97
	DN80	106	97	139	101
	DN100	119	110	166	107

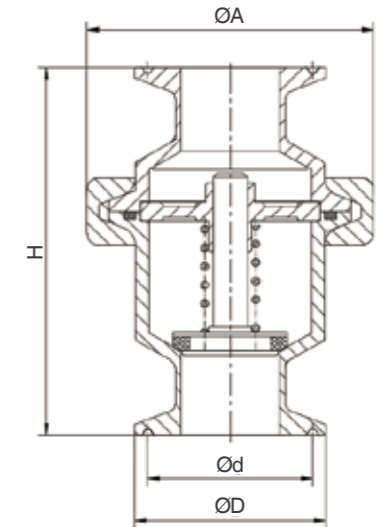

Series W90000

W5000-EN-202506

W5000-EN-202506

Stainless Steel Electric Control Ball Valve

Size: DN15-DN50

Application

Function Control the flow and volume of medium in pipeline.
Application: Urban water supply system, PCW, liquid cooling system and other systems.

Features

- High flow capacity, low resistance loss
- Equal percentage adjustment features
- High protection level
- Short runtime
- Power-off hold and Signal-off hold

Working Principle

The actuator drives the rotation of the valve ball to change the area between the ball and seat by receiving the regulating signal or switching signal, to control the flow rate passing through the valve and realize the automatic regulation function.

Material

Component	Material
Valve Body	Stainless Steel CF8
Valve Cover	Stainless Steel CF8
Valve Ball	Stainless Steel 304
Valve Shaft	Stainless Steel 304
Valve Seat	PTFE+ Graphite
Body Seal Ring	FKM/EPDM
Shaft Seal Ring	FKM/EPDM
Shaft Seal Gasket	PTFE

Product Model

Model	Size	Kvs	Actuator
W98100	DN15	10	W-A13C Series
	DN20	16	
	DN25	20	
	DN32	32	
	DN40	50	
	DN50	65	W-AA1S-2/W-AA1M-2

Model Description

W	WATTS	W	9	8	1	0	0
9	Electric Ball Valve						
Connection							
8: Clamp							
Tunnel Type							
1: EQM							
Control Type							
0: Modulating 1: On-Off							
Material							
0: 304							



Specification

- Nominal Size: DN15~DN50
- Nominal Pressure: PN16
- Working Temperature: -15°C~120°C
- Working Medium: Water, ≤50% ethylene glycol solution
- Connection Standard: Clamp: DIN32676
- Flow Characteristic: EQM
- Closing Differential Pressure: 1400kPa
- Maximum Operating Differential Pressure: 350kPa
- Leakage Rate: Class A

Actuator Parameters

- Power Supply: 10Nm On-Off: 24VAC/DC (220VAC optional)
Modulating: 24VAC/DC
24Nm 24VDC (220VAC, 24VAC optional)
- Protection level: IP54 DN15-40 (IP67 optional)
IP67 DN50
- Ambient Temperature: -20°C~+60°C
- Signal: 2-10V
- Optional configuration of other analog signals

Actuator Series	Torque (N·m)	Size	Runtime s	Power W	Current A
W-A13	10	DN15-40	60*	2	0.08
W-AA1S-2	24	DN50	20	7	0.4

*The Runtime of actuator is adjustable. Please consult for details.

Wiring Diagram

10N.m
Switch:

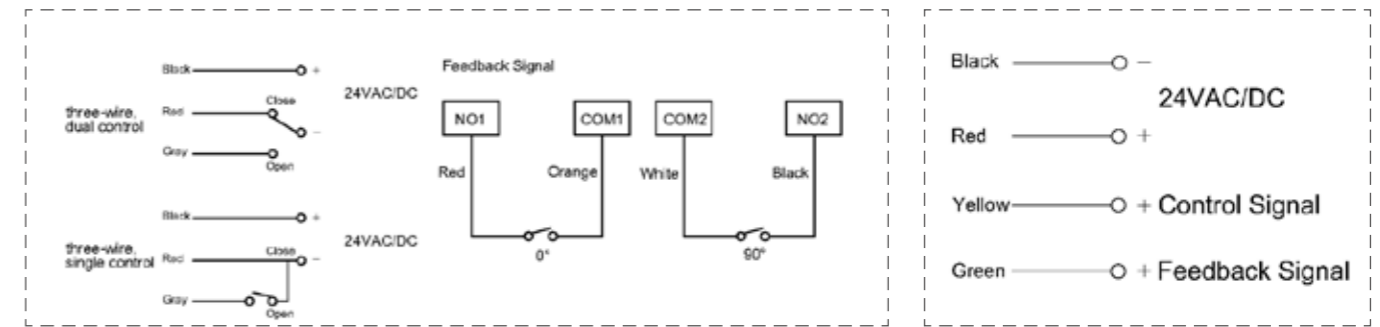

24N.m
Switch:

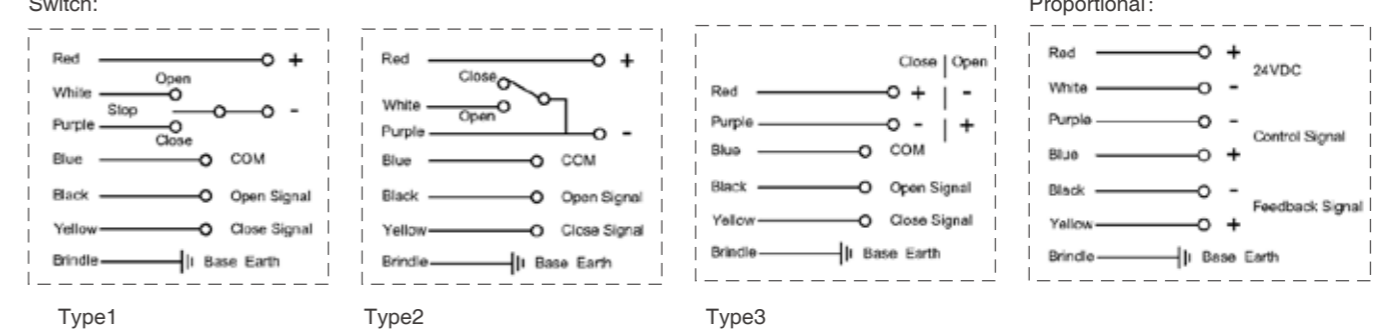

Installation Dimensions

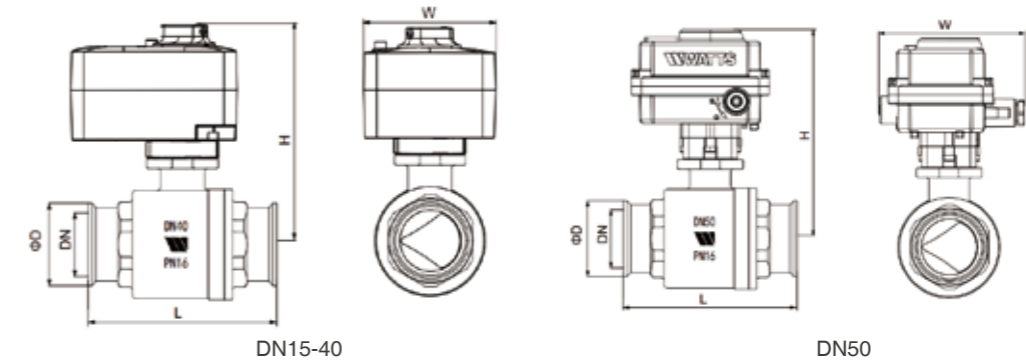

DN	D	L	W	H
15	50.5	95	80	119.5
20	50.5	109.5	80	128.5
25	50.5	112.5	80	132.5
32	50.5	120	80	139.5
40	50.5	132.5	80	143
50	64	146	80	176.2

Installation Instruction

- The two-way control ball valve is recommended to be installed in the return pipe of the system to reduce the thermal stress on the valve.
- Use thread that meets the requirements for connection.
- Please note that the medium flow direction must be consistent with the arrow direction of the valve body during installation.
- The ball valve can be installed horizontally or vertically, but it cannot be installed upside down
- The product leaves the factory in a closed state.

Series W-PQ21X-16P

W-PQ21X-16P EN202506

Stainless Steel Air Vent Valve

Size: DN10-DN25

The devices are used in all traditional plumbing and HVAC systems for discharging air. The air vent valves allow the air to be discharged at the points of the system where it accumulates (distribution manifolds, tops of the risers or directly in the boiler).

Features

- Lever-type sealing mechanism
- Compact, lightweight, simple and reliable structure
- Higher pressure range
- Optional top or side vent function
- Optional automatic sealed shut-off valve

Operating Principles

The automatic operation of the air vent valves is based on a float system ensuring tight seal: valve opening and closing is determined by the float movement (up-down). When there is air in the valve, the force of the float weight acts on the lever which is integral with the plug, thus causing it to move down. In such situation the seat is free and allows the air to be vented outside. When filling the system with water, the air entrapped in the water circuit is pushed towards the outside via the valves. As soon as all the entrapped air is discharged, the water entering the valve body, pushes the float up. Consequently, the lever moves the plug to press against the seat thus ensuring tight sealing of the system, thus preventing the fluid from flowing out.

Material

Components	Body	Bonnet	Sealing	Float
Material	Stainless steel	Stainless steel	EPDM/FKM	PP

Dimensions

DN	G	A	B	C	D	φD
10	3/8"	10	49	7	/	40
15	1/2"	12	49	7	/	40
20	3/4"	18.5	49	7	23.5	40
25	1"	18.5	49	7	23.5	40

Installation and operation instructions

1. Compare the rated parameters required by the equipment with the product parameters to ensure that the product meets the required requirements.
2. Installers shall be subject to training and with experience to ensure that the installation is completed successfully.
3. The air vent valve should be installed at the top of the system or where air accumulates, to ensure maximum air venting efficiency.
4. The air vent valve should be installed vertically so as not to affect the vent function.
5. It is recommended to install it together with the isolation valve for easy maintenance.
6. Use standard-compliant interfaces for connection.
7. After installation, unscrew the end cap by at least 2 turns ensures the vent characteristics.



Technical specifications

- Nominal diameter: DN10~DN25
- Nominal pressure: PN16
- Temperature range: -20°C~110°C
- Medium: water, ≤50% ethylene glycol
- Connection standard: Thread
- Connection standard: ISO 228-1
- Test standard: EN 12266/ ISO 5208

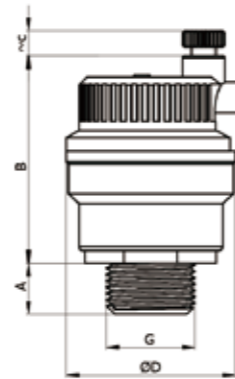

DN10-15

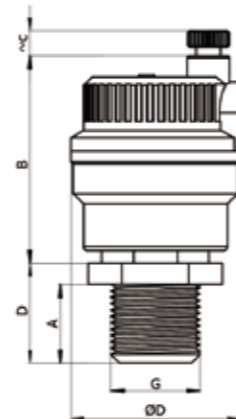

DN20-25

ILBV Series

ILBV-EN-202510

Quick Action Couplings - Interlock Ball Valve

Size: DN25-DN50

ILBV series interlock ball valves are designed for fluid transfer in liquid cooling system of datacenters.

Application

- Function: Control the opening and closing of pipe without the use of tools.
- Application: Liquid supply and return interfaces for high-performance computing (HPC) racks in data centers, thermal management system

Features

- Symmetrical design
- Low connection torque
- Dual interlock safety feature
- High corrosion resistance
- High pressure rating

Material

Component	Material
Valve Body	CF8
Valve Cover	304
Valve Stem	CF8
Sealing	EPDM
Valve Ball	304

Dimensions

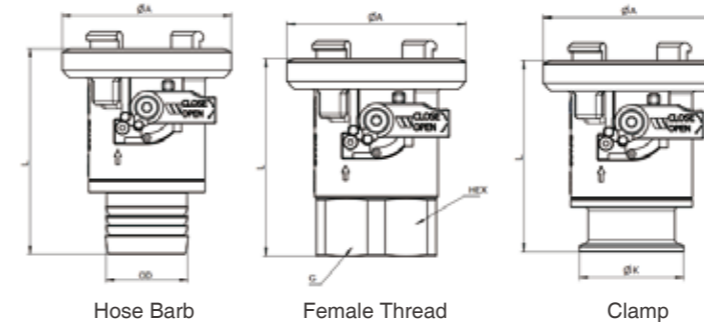

DN	Type	L	φA	OD	HEX	φK
25	Hose Barb	87.7	69.5	27	-	-
40	Hose Barb	103	85.7	42	-	-
50	Hose Barb	113	103.7	55	-	-
25	Female Thread	79.3	69.5	-	40	-
40	Female Thread	94.1	85.7	-	58	-
50	Female Thread	104.6	103.7	-	70	-
25	Clamp	79.3	69.5	-	-	50.5
40	Clamp	91.5	85.7	-	-	50.5
50	Clamp	101.8	103.7	-	-	64



Operating Principles

ILBV series interlock ball valves can't be opened until the two valves are mated, and the two valves can't be disconnected until both valves are closed. Press the pin in handle to operate the valve open or close.

Technical Specifications

- Normal Size: DN25~DN50
- Nominal Pressure: PN16
- Working Temperature: -20°C~120°C
- Working Medium: Water, ≤50% ethylene glycol
- Connection Standard: Hose Barb
Female Thread
Clamp
- Testing Standard: GB/T 13927

Characteristics

DN	Kvs	Fluid Loss
25	23.6	4.3
40	62.0	10
50	100.4	14

Flow Data:

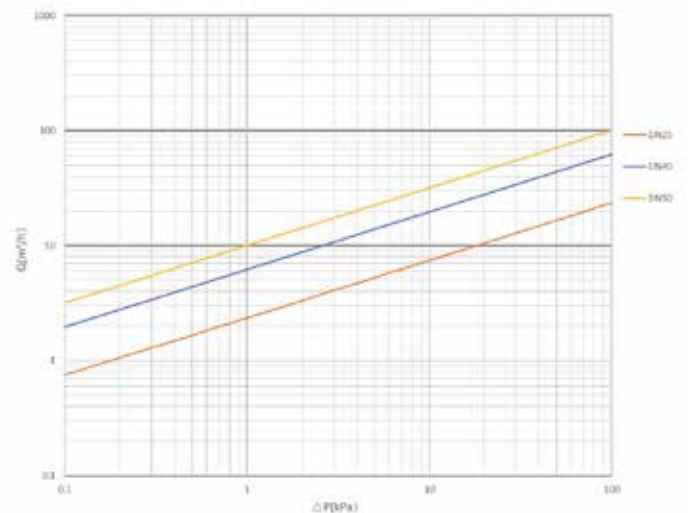

Series W1000

W1000-EN-202507

Miniature ball valve

Size: DN6-DN25

Functions: mainly used to cut off or connect the medium in the pipeline, or regulate and control the fluid
Application area: construction industry, water treatment, etc.

Features

- Integral structure, reliable sealing
- Convenient operation, rapid opening/closing
- Anti-off design valve stem, safe and reliable

Operating Principles

Relying on the handle to drive the valve stem to rotate, the valve stem drives the ball to open and close in the range of 0°~90°

Technical Specifications

- Nominal pressure: PN16
- Applicable temperature: -20°C~120°C
- Applicable media: water, ≤50% ethylene glycol
- Test standard: EN 12266/ ISO 5208
- Connection standard: female and male thread ISO 228-1
For other structure or thread types, please consult

Material

Component	Material
Valve body	Stainless steel
Valve seat sealing	PTFE
Valve spool	Stainless steel
O-ring	FKM/EPDM
Valve stem	Stainless steel

Dimensions

DN	Thread	W	H	D	L
8	G 1/4	22	28	7.5	47
10	G 3/8	22	28	7	45.5
15	G 1/2	22	28	9	50
20	G 3/4	22	31	12.5	55
25	G1	33	38	15	68

If you need other sizes or connection methods, please contact sales representative.

Installation Instructions

- (1) Compare the rated parameters required by the equipment with the rated parameters indicated on the product to ensure that the product meets the necessary requirements;
- (2) Installers shall be subject to training and with experience to ensure that the installation is completed successfully;
- (3) Thorough inspection shall be carried out at the end of the installation to ensure that the installation has been carried out correctly;
- (4) To ensure that there is no accident in the installation work, the piping system shall be thoroughly cleaned (using chemical reagents if necessary) before the installation of the product so as to make sure that the piping system is clean, free of corrosion and dirt and all filtering devices shall be removed to make sure that the piping is smooth before flushing;
- (5) Use standard-compliant threads for connection.



Typical Applications

- Air conditioning system
- Building industry
- Instruments and apparatus
- Industrial equipment

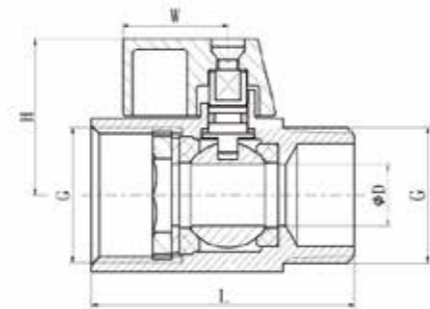

Data Center Project List

Project	Category	Product
Microsoft Middenmeer AMS06	Internet data center	BFV's, BFP's, strainers
Orange Chartres	Enterprise cloud and communication system equipment manufacturer	BFV's manual & automated
Data Center Aruba	Internet data center	BFV's manual & automated
Schiphol Campus	Internet data center	Actuators
Amazon - Emirates	Internet data center	Commodities
Google - Poland	Internet data center	Commodities
Microsoft - Netherlands	Internet data center	Commodities
Keppel Data Center	Internet data center	PVC automated ball valves
Equinix PA9	Internet data center	BFV's manual
Telehouse Data Center	Internet data center	BFV's manual
Orange Val de Reuil	Internet data center	BFV's manual
HostDime	Internet data center	Drains
AWS Data Center	Internet data center	ACV's
Meta Bid 3, 4 Iowa	Internet data center	BFV's
Meta Nebraska	Internet data center	Backflow Preventers
Microsoft DSM40 - Iowa	Internet data center	Backflow Preventers
Cytera IAD 2&3	Enterprise cloud and communication system equipment manufacturer	Valves and Drains
Project Bear	Financial and insurance institution	Drains
Coresite	Enterprise cloud and communication system equipment manufacturer	BFV's
CyrusOne	Enterprise cloud and communication system equipment manufacturer	BFV's
Coresite	Enterprise cloud and communication system equipment manufacturer	BFV's
Cologix	Enterprise cloud and communication system equipment manufacturer	BFV's
Coresite	Enterprise cloud and communication system equipment manufacturer	BFV's
Coresite	Enterprise cloud and communication system equipment manufacturer	BFV's

Project	Category	Product
Range International Information Cloud Fusion Port Project A-3#	IT service provider and data center operator	ECBV/STBV/Strainer
Shandong Mobile Data Center Valve Procurement Project	Integrated telecom operator	BFV/STBV/Safe V./BFP
China Telecom Hebei Data Center	Integrated telecom operator	STBV/BFV/Vent V./CV
China Nuclear Power Research and Design Data Center	Enterprise cloud and communication system equipment manufacturer	BFV/CV/Vent V.
State Grid Hebei Dispatch Communication Production Room Works	Enterprise cloud and communication system equipment manufacturer	BFV/GV/STBV
Baidu Cloud Computing (Yangquan) Phase II Project D13 Module	Internet data center	BFV/Strainer/STBV/GLV
ZhongEn Cloud Data Center Building 8# Project	IT service provider and data center operator	BFV/CV
Aoxin data center project 1.1 phase 2, 4# building	IT service provider and data center operator	BFV
GDS Data Center Shanghai Pujiang 2, 8# Building B	IT service provider and data center operator	BFV/STBV
Nanjing Jishan Telecom III Building B1	Internet data center	BFV/Strainer/STBV
Kunshan Zhongjin Data Center	Financial and insurance institution	BFV/BV
China Mobile Suzhou Data Center	Internet data center	BFV/BV/Strainer
China Mobile Fuzhou Data Center A2#	Internet data center	BFV/ECBV/STBV/Joint/BFV/Strainer
China Mobile Xiamen Data Center	Internet data center	ECBV/GV/Strainer
China Mobile Xi'an Data Center Phase II	Internet data center	BFV/STBV/Strainer
China Mobile Zibo Data Center	Internet data center	Strainer/Strainer/BFV/GLV
China Telecom Cloud Computing (Shanxi) Base Phase II No. 6 IDC	Internet data center	Strainer/BFV/Vent V.
China Mobile Hunan Xiangtan Data Center	Internet data center	BFV/Strainer/ECV
China National Development Bank Xi'an Data Center Project	Financial and insurance institution	Strainer/BFV/GLV
China Mobile Wuhan East Lake Hi-tech Information Port Park (Phase II) Project	Internet data center	STBV/Strainer/CV/BFV
China Unicom Zhengzhou Data Center Project	Internet data center	STBV/Strainer/CV/BFV
Qinghai Haidong Data Center Small E&M Phase IV Expansion Project	IT service provider and data center operator	butterfly valve, strainer, brass globe valve, exhaust valve
Data Center Room of Shunde Agricultural and Commercial Bank Building	Government services cloud	butterfly valve, strainer, static balancing valve, exhaust valve, ball valve, butterfly valve, strainer, static balancing valve, exhaust valve, ball valve
Huazhang Daxing Data Center - Aite Net Energy Section	IT service provider and data center operator	butterfly valve, globe valve, strainer, exhaust valve